

APPLICATION CONDITIONS	MIN.	NOM.	MAX.
TEMPERATURE (°F)			
PRESSURE (PSI)			
SPEED (SFPS)			
STROKE LENGTH (IN)			
CYCLE RATE (CYL/SEC)			
MEDIA			

BILL OF MATERIALS				
ITEM	QTY	PART#	MATERIAL	DESCRIPTION

REVISIONS				
ZONE	REV.	DESCRIPTION	DATE	ECN #

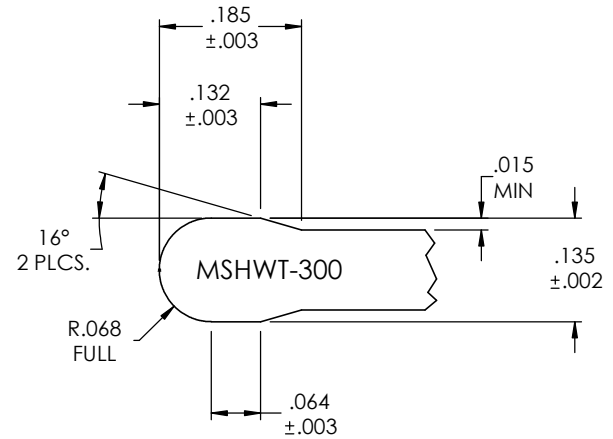
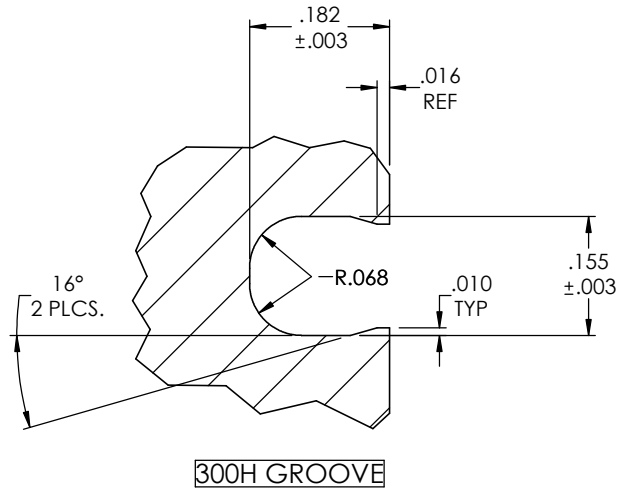

----- Q

UNLESS OTHERWISE SPECIFIED:	NAME	DATE
DIMENSIONS ARE IN INCHES	DRAWN L. DOUGLAS	12/6/17
TOLERANCES:	MFG REVIEW	
FRACTIONAL ± 1/16"	ENG APPR. [Signature]	12/6/17
ANGULAR: ± .5°		
TWO PLACE DECIMAL ±.01		
THREE PLACE DECIMAL ±.005		
JACKET MATERIAL:	COMMENTS:	
SPRING TYPE: 300 HELICAL		
O-RING:		
DO NOT SCALE DRAWING		

PROPRIETARY AND CONFIDENTIAL
 THE INFORMATION CONTAINED IN THIS DRAWING IS THE SOLE PROPERTY OF MW INDUSTRIES, INC. ANY REPRODUCTION IN PART OR AS A WHOLE WITHOUT THE WRITTEN PERMISSION OF MW INDUSTRIES, INC IS PROHIBITED.

 MAUDLIN PRODUCTS. MW Industries, Inc.		
TITLE: GENERAL ARRANGEMENT 300 HELICAL SPRING GROOVE AND TOOL		
SIZE A	DWG. NO. MSHWT-300	REV
SCALE: NTS		SHEET 1 OF 1