

APPLICATION CONDITIONS	MIN.	NOM.	MAX.
TEMPERATURE (°F)			
PRESSURE (PSI)			
SPEED (SFPS)			
STROKE LENGTH (IN)			
CYCLE RATE (CYL/SEC)			
MEDIA			

BILL OF MATERIALS				
ITEM	QTY	PART#	MATERIAL	DESCRIPTION

REVISIONS				
ZONE	REV.	DESCRIPTION	DATE	ECN #

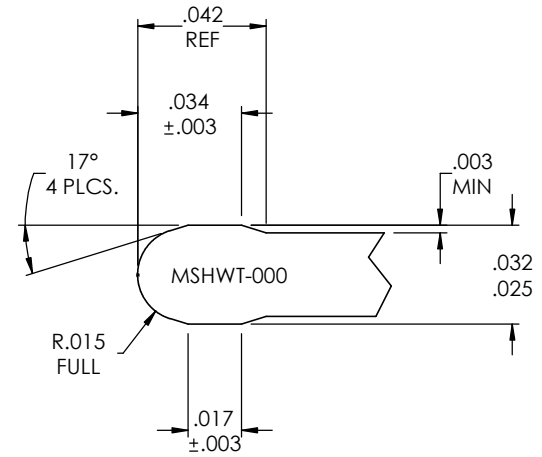
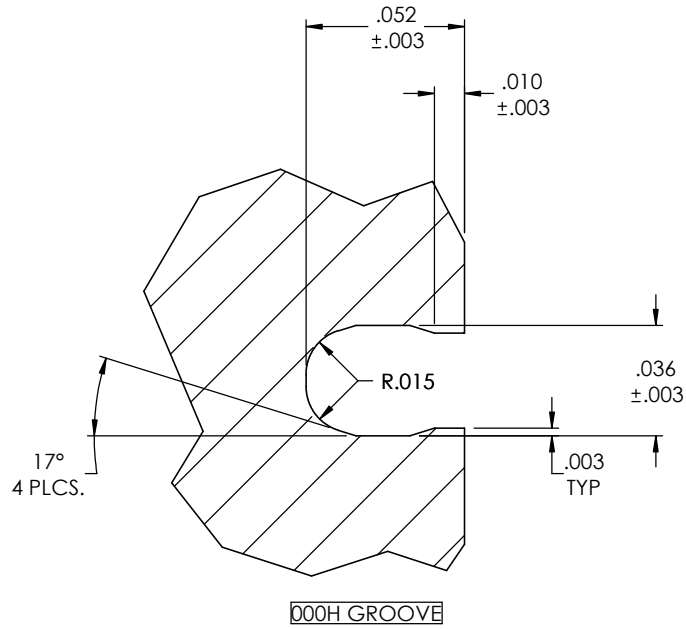

----- Q

UNLESS OTHERWISE SPECIFIED:

DIMENSIONS ARE IN INCHES
TOLERANCES:
FRACTIONAL ± 1/16"
ANGULAR: ± .5°
TWO PLACE DECIMAL ±.01
THREE PLACE DECIMAL ±.005

JACKET MATERIAL:

SPRING TYPE: 000 HELICAL

O-RING:

DO NOT SCALE DRAWING

	NAME	DATE
DRAWN	L. DOUGLAS	12/1/17
MFG REVIEW		
ENG APPR.		12/1/17

COMMENTS:



TITLE:
GENERAL ARRANGEMENT
000 HELICAL SPRING
GROOVE AND TOOL

SIZE	DWG. NO.	REV
A	MSHWT-000	

SCALE: NTS SHEET 1 OF 1

PROPRIETARY AND CONFIDENTIAL
THE INFORMATION CONTAINED IN THIS DRAWING IS THE SOLE PROPERTY OF MW INDUSTRIES, INC. ANY REPRODUCTION IN PART OR AS A WHOLE WITHOUT THE WRITTEN PERMISSION OF MW INDUSTRIES, INC IS PROHIBITED.